

New York

Empire



New York Empire

The New York series of wall-hung bioethanol fireplaces comprises the most popular models from **decoflame®** as they fit into every modern home and provide an impressive effect.

The New York Empire is the largest model in this series of **decoflame®** fireplaces. It is available in several different finishes and can be manufactured according to special requirements in colour and size. The Empire is ideal for creating a cosy atmosphere in a more spacious setting and works well as supplement to existing heating systems. In a room of 30-40 square meters it can raise the temperature by around 3-8 degrees centigrade. This model is installed easily and comes with an adjustable burner.

Specifications

Materials:
Steel and stainless steel.

Finishes:
Brushed, polished (mirror-finish) and powder-coated.

Heat efficiency:
Approx. 3.2 kW

Burner volume:
4.3 litres of bioethanol. Use only bioethanol for **decoflame®** fireplaces.

Burning duration:
One filling of bioethanol will burn 4 - 8 hours depending on flame intensity and air flow.

Dimensions:

Weight: 26.6 kg

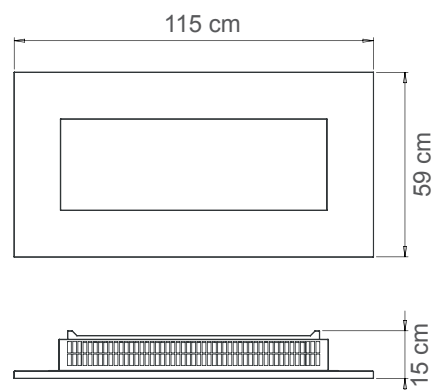

decoflame®
Odor- and smokeless bio fireplaces

Design: Kjell Thomsen